

Item Name
商品名称

DM50-15

Built in Encoder and driver, I2C bus interface
Ultra high torque, precision control



DIMENSION

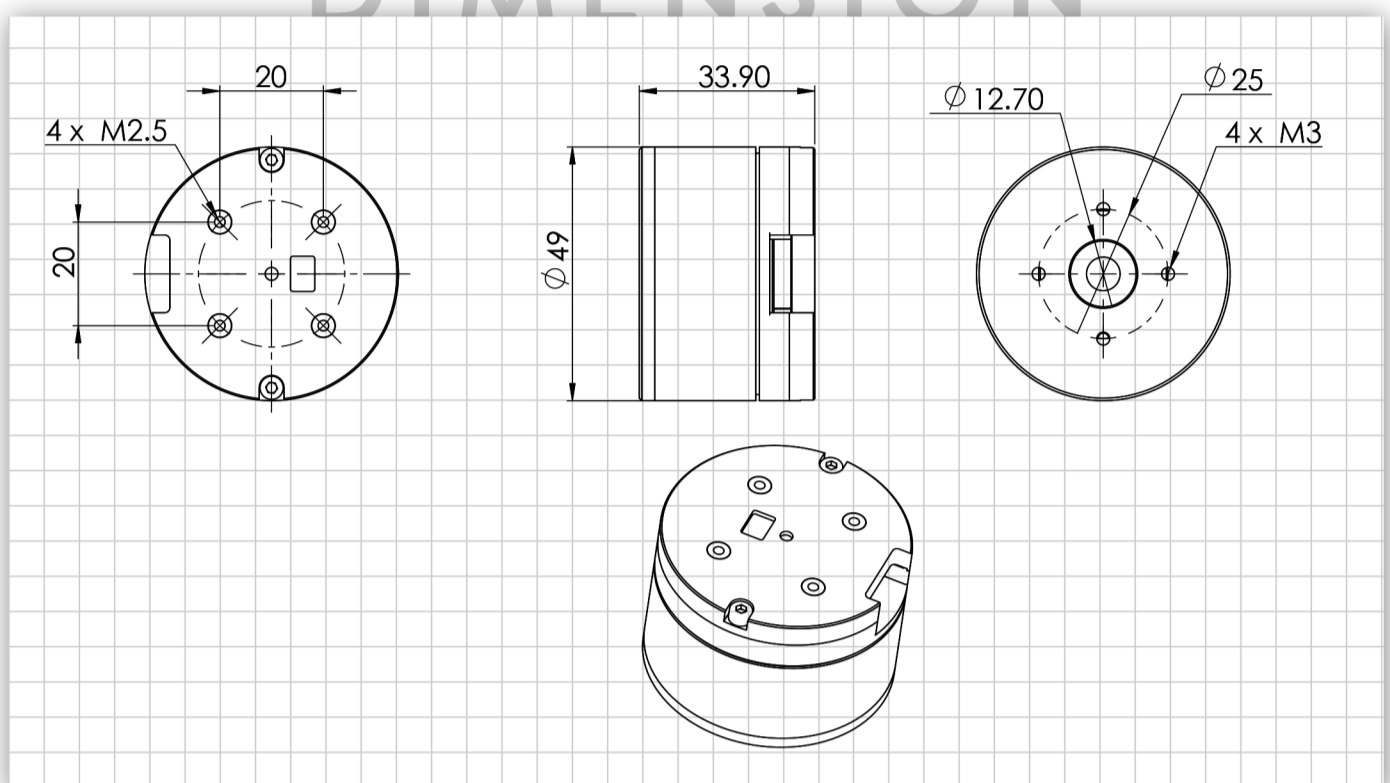

SPECIFICATION

型号 (item name)	DM50-15
重量 (weight;g)	170
尺寸 (Dimension;mm)	49x33.5
结构 (configuration)	24N28P
电机输入电压 (input volatge)	10.5-21.0V
电机阻值 (resistance)	13.20
驱动器 (drive board)	sinewave driver
驱动器输入电压 (Drive board voltage)	10.5-21.00V
驱动允许最大电流 (max current)	2.5A
中孔直径 (hollow diameter;mm)	12.6
电机安装孔 (motor fixed diameter)	20, 4xM2.5
最大负载 (max payload, kg)	3.0

Actual measurement by GYEMS technical team

ACCESSORIES



DIMENSION

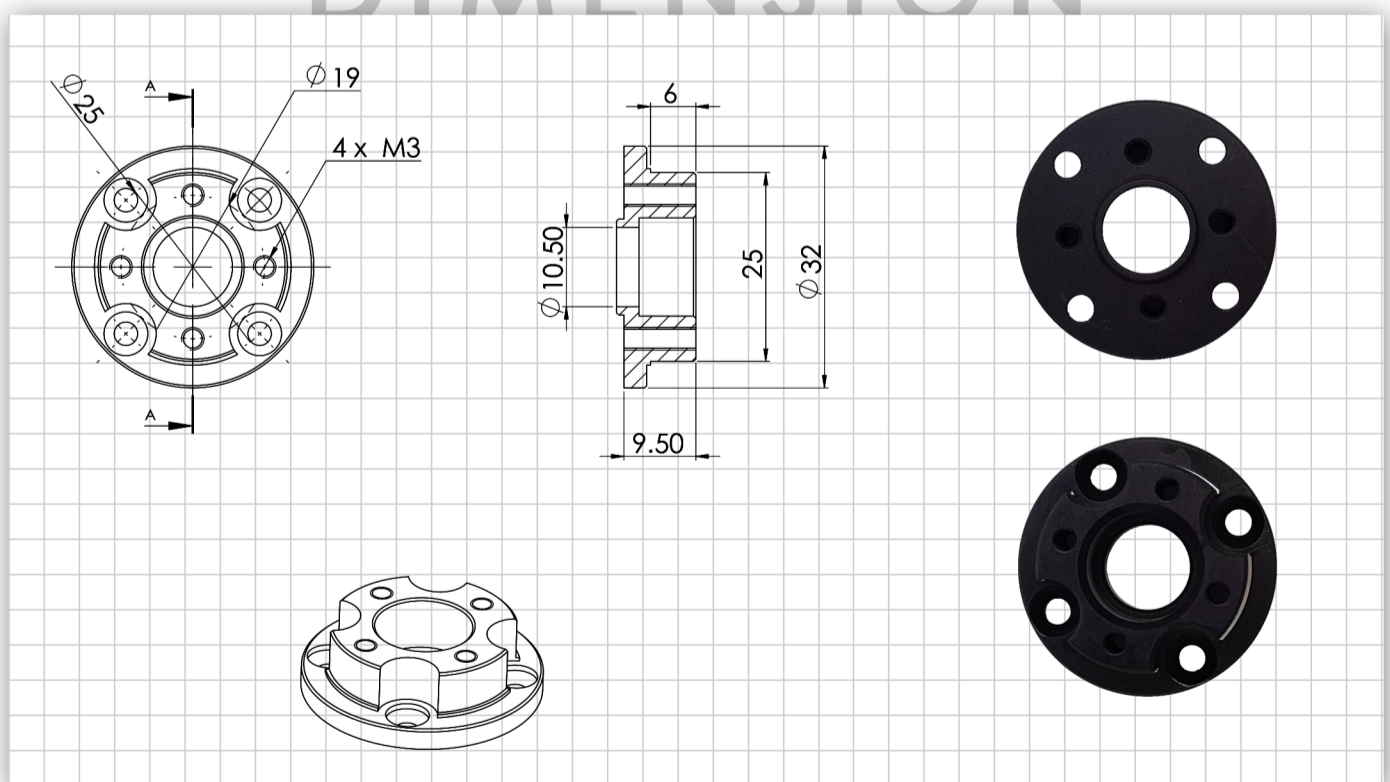

DIFFERENT SIDES

